

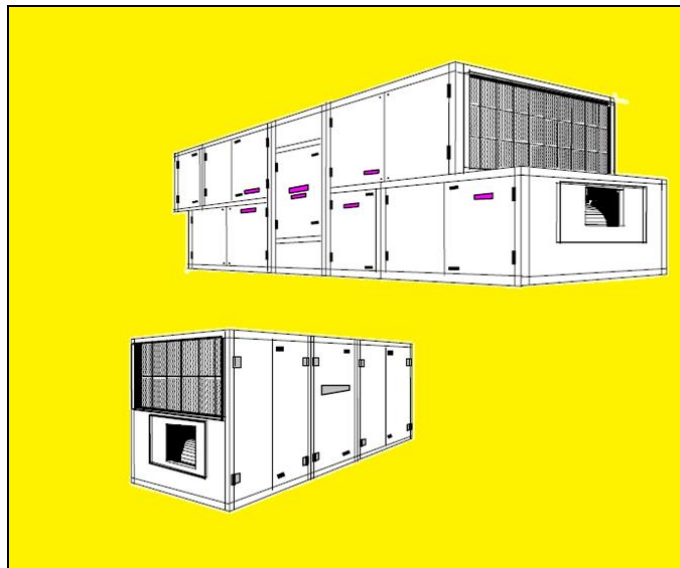

TEMPEFF

Installation and Maintenance Manual

RG Series



For long term reliability and proper function of Tempeff equipment, it is essential that these instructions are followed.

These are general instructions, valid where applicable

For more detailed assembly instructions visit:
[www.tempeff.com/assembly instructions rg.pdf](http://www.tempeff.com/assembly%20instructions%20rg.pdf)



Tempeff Inc.
675 Washington Ave
Winnipeg, MB Canada
R2K 1M4

Ph: (204) 783-1902

www.tempeff.com



Bulletin No. IM 2-1
November 2019



Index	Page 1
General and Storage	Page 2
Instructions for lifting with a Crane.....	Page 3
Mounting the individual sections	Page 4
Split sections.....	Page 5
Suggested framework	Page 5
Hanging the unit.....	Page 6
Fitting Heat Exchanger Cells into RG units.....	Page 6
Connecting Heating and Cooling Coils.....	Page 8
Installing Condensate Drain Traps.....	Page 8
Installation Requirements	Page 9
Before Start-up Instructions	Page 9
Start-up/Commissioning Procedure.....	Page 10
Maintenance Instructions.....	Page 11
Bearing Installation and Maintenance.....	Page 11
Lubrication Charts	Page 12
Tensioning V-belts.....	Page 13
Warranty	Page 15
Schneider M172P Contoller Guide	Page 16
Start Up Sheets.....	Page 21



FOR TEMPEFF AIR HANDLING UNIT WITH DUAL CORE HEAT EXCHANGERS

General

The instructions for assembly, operating and maintenance must be followed carefully in order to achieve short and long term function and reliability. It is also a prerequisite for the warranty to apply.

This manual shall be easily accessible to the staff responsible for the operation of this unit.

If the product is modified or changed without consent or instruction from Tempeff the ETL listing (if applicable) may no longer be valid, and the warranty may no longer be valid.

Due to the custom nature of the product not all cases are covered in this manual. In the cases where special items are included in the product, specific instructions can be obtained from the local authorized Tempeff Representative, or by contacting the Tempeff Factory.

Intended Use

The unit is intended for comfort heating/cooling use only with no mixing of corrosive or flammable gases.

Storage

Failing to follow the enclosed instructions may cause damage to the equipment, and void warranty.

- 1) When storing both indoor and outdoor units, openings and access doors must be sealed
- 2) Equipment must be adequately protected from weather until final installation is complete. Equipment stored outdoors must be heated. NOTE: Factory shrink wrap or poly is not considered sufficient protection against the weather when stored in an area exposed to the elements. The contractor is responsible for fully tarping the equipment to prevent damage from weather or construction damage.
- 3) During extended periods of storage, it is important to rotate the fan and motor bearings by hand at least once a month to prevent bearing damage. The bearings should also be greased at the same frequency. Ensure bearings are not over greased as it may result in ruptured seals and premature bearing failure once in operation.
- 4) To ensure equipment stays in as-shipped condition, and to avoid corrosion, inspect the equipment twice weekly while in storage. If moisture is discovered on the surface of the equipment immediately heat and ventilate the equipment to prevent corrosion.
- 5) On RG units sized 7500 and larger, the damper motors should be powered and cycled every 6 months. If power is unavailable, insert a 6mm hex wrench into the damper motor and rotate one full revolution by hand. There is a hole located in the center of the damper motor fan shroud for this purpose. Repeat for all required damper motors. See following picture.

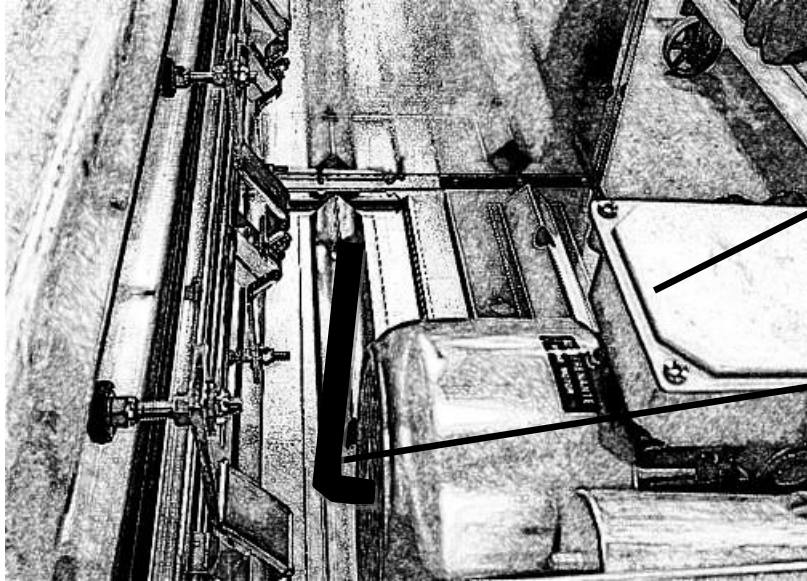

Damper Actuator

6mm Hex Wrench

Instructions for lifting with a Crane

LIFT
With soft straps under the unit. Ensure that the straps are secured so they don't glide off.

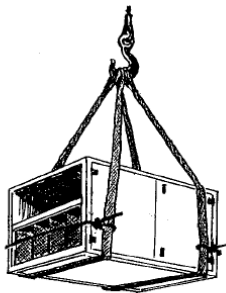
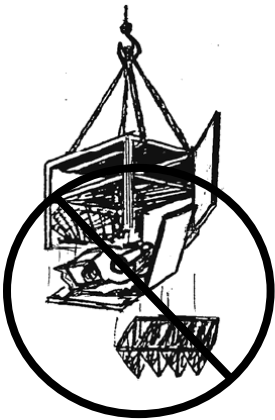

When using lifting lugs to raise the unit spreader bars must be used to prevent damage to the equipment. If lifting lugs are not present each unit must be lifted with soft straps under the lower framework. Since the profiles used are slippery, the soft straps must be secured to keep the straps from sliding off.

The unit is not designed to carry its' own weight from the upper framework.

Occasionally, the aluminum heat exchanger cells may be delivered inside the heat exchanger section. **All heat exchanger cells must be unloaded before lifting and reinstalled after the unit is in place.**

WARNING!

The upper framework and/or extending parts of the unit may not be used for lifting.

Mounting the individual sections

Unit shall be placed on a solid and bare surface suitable for the present environment and installation, such as elevated for drain connection if applicable.

Due to the weight of the heat exchanger cells it is necessary to ensure that all parts of the unit are well supported, not only under the outer framework but also in between the outer frame. (See Suggested Framework, Page 5)

Diagram 1 & 2: self-adhesive gasketing(A) shall be used where the units connect to each other. Suitable high quality caulking may be used in lieu of gasket. (Page 4)

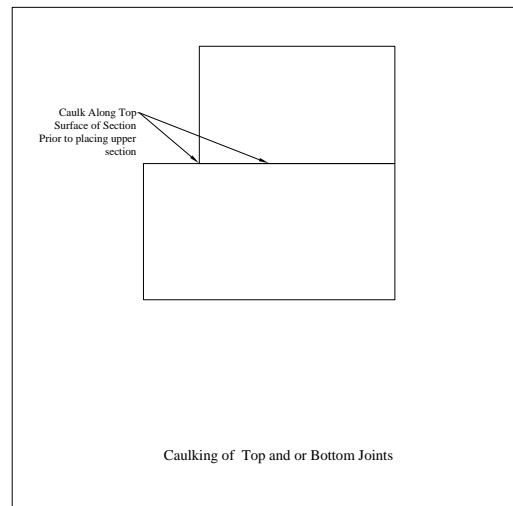
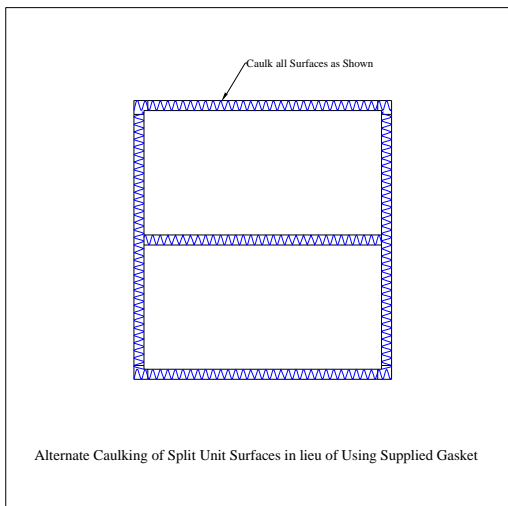
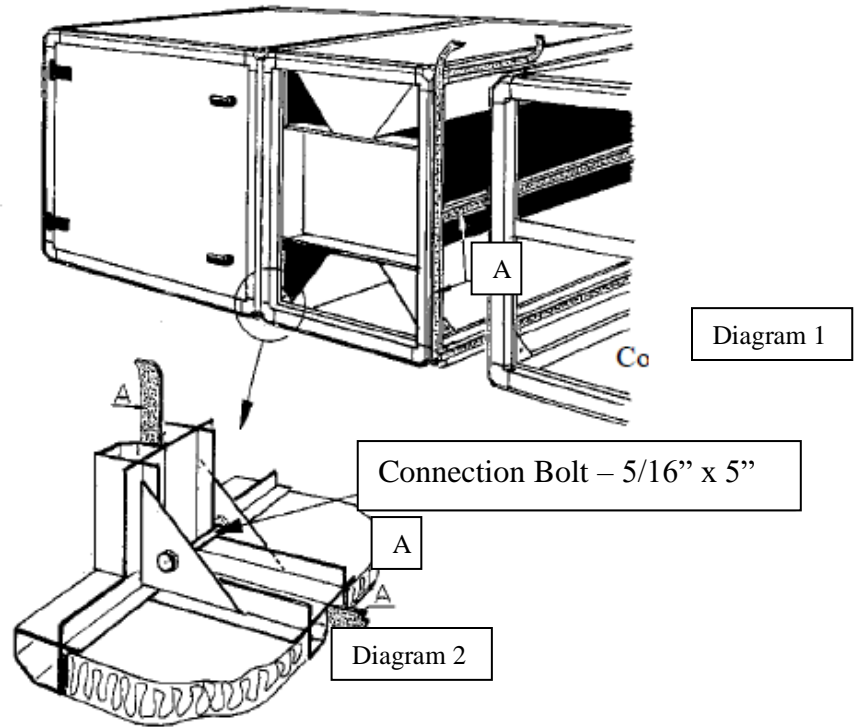

Outdoor units with sections stacked one on top of the other should be caulked prior to placing the section on the other.

For each split on an outdoor unit a split cap is provided to bridge the roof splits. This cap is an integral part of the roof structure and must be installed. Pre-drill pilot holes on side of cap, then fasten using common sheet metal screws. A minimum of 2 screws per side are required.

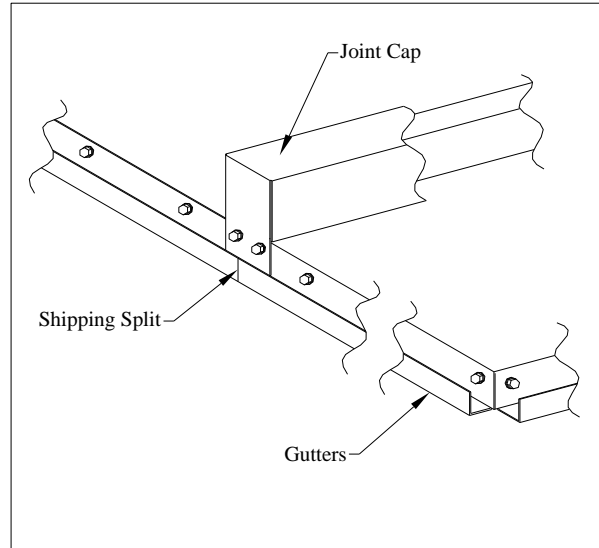

Suggested Framework

The unit shall be assembled on a solid and plain surface. A frame of square steel bars is recommended. It must be supported at each end and at each unit connection. Support leg to slab, or rod from roof shall also be fit at each end and each unit connection as shown on the picture.

When designing the frame, the weight of the unit must be accounted for. Note that the weight of the heat exchanger cells makes the units heavier than traditional AHU's.

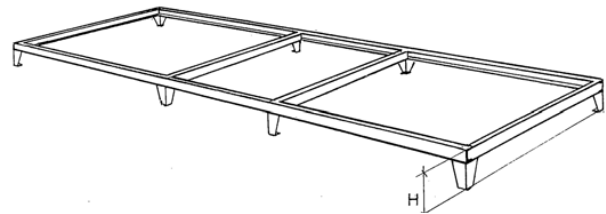

Therefore, units with widths greater than 1.5m (4.92 feet) must be supported by two outer bars. Max width between bars is 800mm (32 inches).

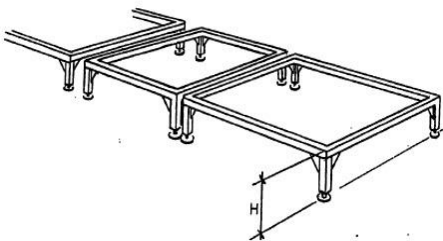

Smaller RG units can be mounted directly on rigid mineral fiber insulation boards placed on the floor slab if it is level and if a water drain trap is not required.

Leveling (to within 1/8" per 10 ft) shall be made using water level or laser instrument. If the unit requires a water drain trap the height of the legs shall be calculated accordingly. See page 8 for details.

Hanging the unit

If the unit is to be hung, it must rest on a framework supported by rods hanging from the roof.

Support rods shall be centered with the connections between the sections of the unit and the connection points between the rods and the frame shall be located so that the rods don't interfere with the opening of the doors or the connection of ducts.

When designing and building the supporting frame work (by others) and rods, the weight of the unit must be taken into consideration. The heat exchanger cells make the units heavier than traditional AHU's. Level to within 1/8" per 10 ft.

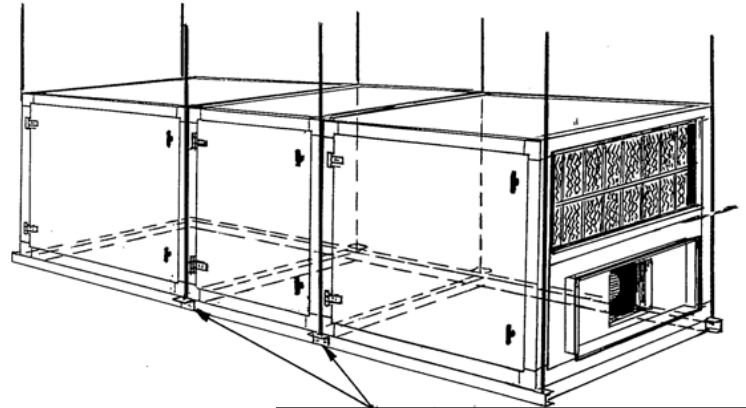

Rods connect to the framework (supplied by others) outside the unit and center with the unit section connection point.

Fitting of Heat Exchanger Cells into RG units

Care in handling of the aluminum heat exchanger cells must be taken. For functional reasons the cages are quite small and therefore subject to deformation if treated roughly.

Heat exchanger cells are normally delivered wrapped standing on a pallet. When the wrapping is removed, ensure that the packs don't fall. If they do fall, they normally take on a rhomboid form and they must be reformed to square before being fitted into the chamber.

This must be done by hand! The resistance that needs to be overcome is largely friction between the plates.

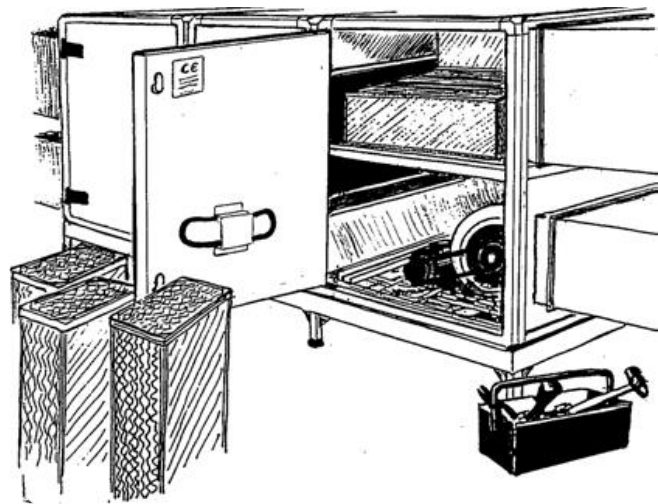

Occasionally, the heat exchanger cells may already be installed in the chamber. They must be taken out before erection of the unit and reinstalled after.

The heat exchanger cells shall be slid into position on the supports in the drain pan. They must be installed properly, following the cell layout label inside the heat exchanger door; otherwise the doors may not close.

When the unit contains cell more than one row high, they should be slid in on the supplied cell separator angles. These angles should be placed at the ends of the cells, short angle facing up, so the next layer of cells slide in on the angles.

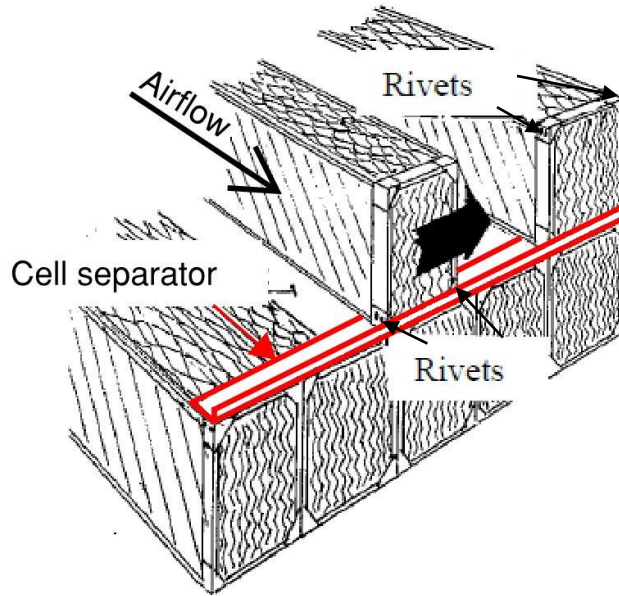

Some unit sizes have one set of heat exchanger cells of different size than the others. These have a different depth and shall be installed last, closest to the inspection door on each row. For reference, cell layout diagrams can be found inside the door of the heat exchanger sections.

NOTE!

Due to exact tolerances, the rivets MUST be oriented so that they do not contact each other. Turn the cells so that one set of rivets is on top, and the next is on the bottom. See below.

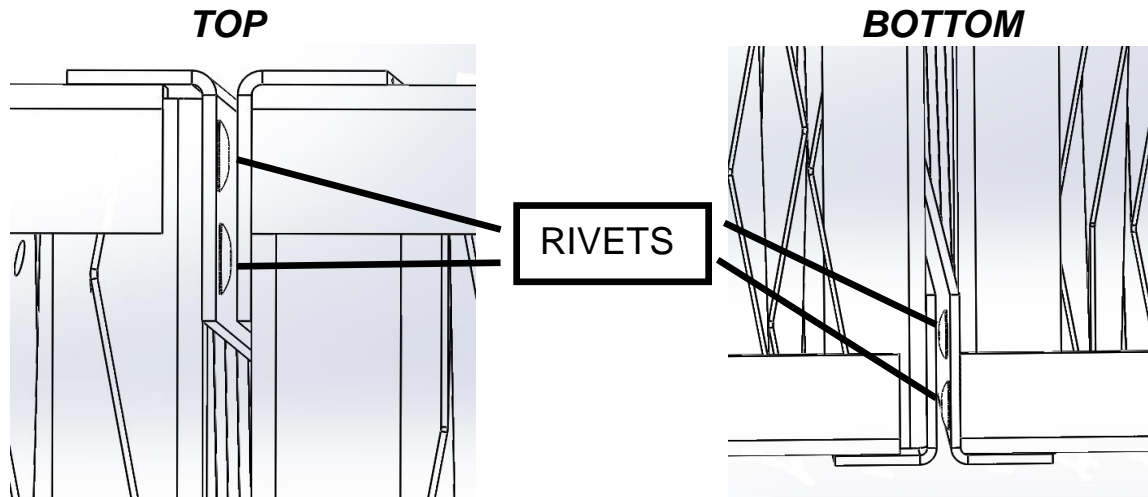

Failure to properly align the rivets can cause the overall width of the heat exchanger cells to increase significantly. The cells will not fit in the drain pan and the door will not close!

Connecting Cooling and Heating Coils

In all cases, coil manufacturers installation instructions take precedence. Please note that the change over damper section is not spring return so it should be disabled in the closed position before disabling power.

With water coils, ensure the connections are made so that leaving water from the coil is what the entering air sees (counterflow).

Mounting an anti-freeze protection device on water coils is strongly recommended to prevent damage to the coil due to freezing. Frost damage is not covered by warranty.

When installing couplings, do not apply undue stress to the connection. Use a backup pipe wrench to avoid breaking the weld between coil connection and header.

Ensure care is taken when handling and connecting coils. Connections and pipes are fragile, and can easily be damaged.

Installing Condensate Drain Traps

Units equipped with optional drain connection must have drain traps field provided and installed on each drain. On both blow-through and draw-through units, the trap depth and the distance between the trap outlet and the drain pan outlet should be twice the static pressure in the drain pan section under normal operation for the trap to remain sealed. For example if the pressure is 2" W.C, 2P will be 4" deep.

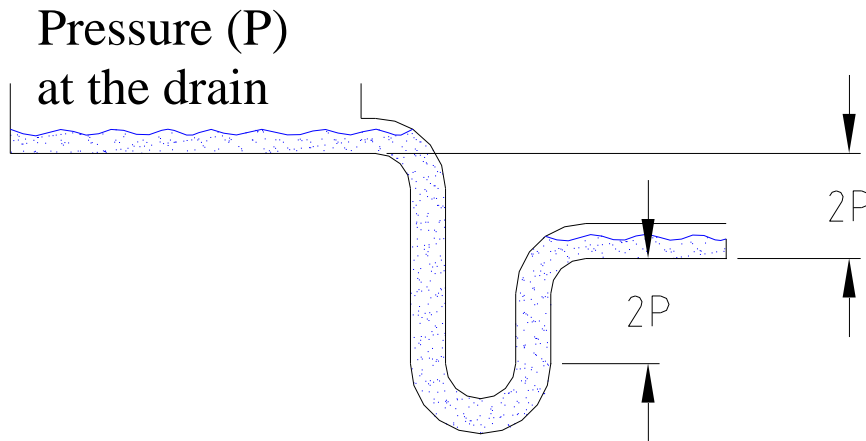

This height will also determine the height H of the mounting framework as detailed on page 4. H should be 4P, plus 2".

IMPORTANT NOTE: If Traps are to operate when located in cold areas (ie. Outdoor mounted units, heat exchanger condensate drains) it is recommended that the trap and any drain lines be heat traced **and** insulated for reliable operation in cold temperatures.



Installation Requirements

1. Service clearances must be maintained on the access side of the unit. Recommended minimum clearances are equal to the section length if unit is equipped with single door, or section length/2 if unit is equipped with double door, as clearance must be sufficient to open doors. Consult dimensional diagram to verify required service clearances.
2. All relevant local and national codes (NEC or CEC) must be adhered to for clearances to electrical connections. 1m or 36 inches is the minimum from the face of any electrical enclosure to any wall or obstruction.
3. Installer is responsible for checking all damper bolts, linkages and blades to ensure tightness, as during shipping these bolts may become loose.
4. Installer is also responsible for checking tightness of all electrical terminals and connections, as these connections may become loose during shipping and result in performance issues.
5. Consult wiring diagram to verify which electrical connections must be made in the field, such as unit power, and field connections for the damper to be controlled by BMS. All wiring must be performed in accordance with all applicable codes and ordinances. Warranty is voided if wiring is not in accordance with these standards.
6. If unit is controlled by BMS, controls contractor must ensure the dampers are first on and last off (after the blowers have been shut down) to avoid damage to the dampers.
7. If unit is equipped with blowers, ensure that shipping blocks have been removed from isolation frame.

Before Start-up



1. Ensure that unit is completely and properly installed, and all ductwork is connected. Ensure that all construction debris has been removed, and that filters are clean.
2. Verify that all electrical connections have been made, and check to ensure that correct voltage has been applied to the appropriate sections. Check to ensure electrical connections are tight.
3. Rotate the fans manually to ensure they rotate freely. Check to ensure that belts have been tightened and sheaves aligned using a straight edge.
4. Verify that all damper blades close properly. Blades should be tight enough that a finger cannot be pushed through but not so tight that the damper blade causes the housing to deflect. Excessive tension can cause damage to damper section.
5. Check setscrews and nuts/bolts in damper linkages, bearings and fan wheels (if unit is equipped with blowers). **Note that equipment damage due to loose fasteners is improper start-up and will not be covered under warranty!**
 - a. **After 48hrs:** Ensure unit has been properly locked out. Check tightness of all damper linkage, bearing, wheel and sheave setscrews.
 - b. Check belt tension.
6. Verify that all penetrations through the unit casing (Electrical, drainage, etc.) are sealed properly to prevent water leakage into the unit and/or the building.

Start-up/Commissioning procedure

When performing start-up and service, thorough safety precautions must always be taken. These functions must always be performed by trained, experienced personnel. View “Before Start-up” description before attempting start-up.

 WARNING
FIRE/ELECTRIC SHOCK HAZARD.
Can cause property damage, personal injury or death. Fan power supply must be wired and motor frame grounded in accordance with local electric codes.
 AVERTISSEMENT
Risques d'incendie et d'électrocution pouvant causer des dommages matériels, des blessures et même la mort. L'alimentation électrique du moteur du ventilateur de même que la mise à la terre du châssis du moteur doivent être faits conformément aux codes d'installations électriques en vigueur.

 WARNING
ROTATING FAN
Can cause severe injury or death. Before servicing fans, lockout and tag out power.
 AVERTISSEMENT
PIÈCES MOBILES DANGEREUSES.
Avant de réparer ou entretenir les ventilateurs, coupez l'alimentation électrique de cet appareil et bloquez le commutateur à OFF.

 WARNING
FAN MOTOR REQUIRES OVERLOAD PROTECTION.
Failure to provide motor overload protection can result in fire, property damage, electric shock, personal injury or death. Connect motor to an overload protective device rated in compliance with local electric codes.
 AVERTISSEMENT
Risques d'incendie et d'électrocution pouvant causer des dommages matériels, des blessures et même la mort. Connecter au moteur du ventilateur électrique un dispositif de protection contre les surcharges conforme aux codes d'installations électriques en vigueur.

1. Verify that there is power to the fan motors
2. Verify that there is power to the unit control cabinet (consult wiring diagram for unit control cabinet power terminals)
3. Enable supply air fans and exhaust air fans, and check for correct rotation. If incorrect rotation, correct wiring to ensure fans rotate in proper direction.
4. Check supply and exhaust motor amp draws against rated amp draw on motor rating plate.
5. Test operation of damper motors.
 - a. Put switch S1 in position 1. Actuator M7 should operate continuously.
 - b. Put switch S1 in position 2. Actuator M6 should operate continuously.
 - c. If unit is pneumatic, consult sequence in shop drawing package to verify proper damper motor testing
 - d. Put switch S1 back in position 0.
6. Put switch S2 in position 0. Check to see if dampers are in a “+” formation inside of unit, closing off all air to building. Ensure all blades are firmly closed with no gaps.
7. Put switch S2 in position M. If Ambient air is above 68 deg F (20 deg C), increase temperature on thermostat GT2 (exhaust t’sat) until it is above ambient temperature. If expected supply air is above 59 deg F (15 deg C) increase temperature on thermostat GT1 (supply t’sat) until it is above expected temperature. Dampers should now cycle every 60 seconds.
8. Change GT2 back to 68 deg F (20 deg C), and GT1 back to 59 deg F (15 deg C). If the unit is to be operated as a standalone unit, leave the S2 switch in M mode. If the BMS is to operate the unit, put the S2 switch in A mode.
9. If the unit is controlled by BMS, contacts are used to control the damper mode. Consult the wiring diagrams & sequence to verify wiring. Ensure dampers are first on and last off (after blowers shut down) to avoid damage to dampers.
10. If unit does not operate as expected, consult wiring diagram and begin troubleshooting wiring with your voltmeter. Ensure all wiring terminations have been tightened.

Regular maintenance is necessary to ensure the efficient operation and long life of this unit. This maintenance should be performed by, or supervised by qualified service personnel. A maintenance schedule should be prepared for the unit based on its application and location.

Recommended Monthly Maintenance

1. Check for loose connections in the wiring
2. Check the voltage at the unit while it is in operation.
3. Check motor amperage draws against the rating plate values.
4. Inspect all contactors to ensure that they are clean and making good contact.
5. Clean or replace air filters if necessary.
6. Check all damper, linkages and damper actuators, adjust and tighten as required.
7. Check all belts; adjust or replace as necessary.
8. Check operation of all safety controls.

Recommended Yearly Maintenance

1. Perform the monthly maintenance recommended.
2. Inspect the blower wheels and housing; clean if necessary
3. Inspect all setscrews on blower wheels and pulleys to ensure they are secured to their respective shafts.
4. Inspect all operating and safety controls; clean and replace if necessary.
5. Inspect heat exchanger cores, clean if necessary.
6. Inspect damper linkage for wear or play. Grease all linkage ends with Grade 2 Lithium based grease.

Heat Exchanger Maintenance

1. Perform the Yearly Maintenance as recommended.
2. Visually inspect the heat exchanger cells for buildup of dust and debris.
3. If the heat exchanger cells require cleaning, remove them from the unit.
4. Wash the cells using a pressure washer, then allow them to drip dry.
5. Install the heat exchanger cells back into the unit, as per the manual. Follow the orientation labels on the inside of the heat exchanger doors. Don't forget to alternate the rivets and replace the cell separators!

BEARING INSTALLATION AND MAINTENANCE

NOTE: To prevent premature failure – please ensure greasing instructions below are applied. As well, tighten bearing set screws, collars, and wheel lugs every four to six months.

BALL & ROLLER BEARINGS LUBRICATION

For bearings that are equipped with a hydraulic grease fitting threaded into the housing the proper amount of lubricant in the bearing is important. Both excessive and inadequate lubrication may cause failure.

The bearings should be re-lubricated while they are rotating (if it is safe to do so); the grease should be pumped in slowly until a slight bead forms around the seals. The bead in addition to acting as an indicator of adequate relubrication provides additional protection against the entry of foreign matter and helps flush out contaminants in the bearing.



By the time the slight bead has formed, it will be noticed that the bearing temperature will rise. It is not uncommon for the temperature to raise as much as 30°F after re-lubrication. If necessary to re-lubricate while the bearing is idle, refer to the recommended re-lubrication grease chart tables on the following page for various sizes of the bearings.

LUBRICANT - STANDARD BEARINGS

All bearing units are pre-lubricated at the factory with lithium soap grease, which is compatible with multi-purpose grease readily available from local suppliers. The lubricant selected for factory lubrication uses a highly refined mineral oil with a high viscosity index, thickened with lithium soap to conform to NLGI grade 2 consistency. A suitable additive package is added to protect the highly polished rolling contact surfaces from corrosion and oxidation of the lubricant. The lubricant is satisfactory for an operating temperature range of -30°F to +250°F.

Select standard industrial grade greases that conform to the following specifications for optimum bearing performance:

General Duty Ball & Roller;
58-75 SUS @ 210°F
450-750 SUS @ 100°F

Premium Duty Ball & Roller;
68-75.1 SUS @ 210°F
600-750 SUS @ 100°F

Heavy Duty Roller Bearing;
82 SUS @ 210°F
886 SUS @ 100°F

NOTE: For heavy loaded roller bearing applications, grease with EP additives is often recommended for optimum performance.

TABLE: RECOMMENDED LUBRICATION

Ball Bearings		Roller Bearing	
Shaft Size (inches)	Grease Charge (ounces)	Shaft Size (inches)	Grease Charge (ounces)
¼ to 3/16	0.03	1-3/16 to 1-1/4	0.1
½ to ¾	0.1	1-3/8 to 1-7/16	0.22
1-1/4 to 1-1/2	0.15	1-1/2 to 1-11/16	0.32
1-11/16 to 1-15/16	0.2	1-3/4 to 2	0.5
2 to 2-7/16	0.3	2 to 2-3/16	0.55
2-1/2 to 2-15/16	0.5	2-1/4 to 2-1/2	0.65
3 to 3-7/16	0.85	2-11/16 to 3	0.85
3-1/2 to 4	1.5	3-3/16 to 3-1/2	1.25
-	-	3-15/16 to 4	2.5
-	-	4-7/16 to 4-1/2	3.1



Frequency of re-lubrication depends on operating conditions. The bearing operating temperature is the best index for determining a re-lubrication schedule. The following chart gives the

frequency of re-lubrication based upon continuous operation for various operating temperatures and can be used as a satisfactory guide for determining when bearings should be re-lubricated.

TABLE: LUBRICATION FREQUENCY

Speed	Temperature	Cleanliness	Greasing Interval
100 RPM	Up to 120 °F	Clean	5 months
500 RPM	Up to 130 °F	Clean	2 months
1000 RPM	Up to 210 °F	Clean	2 weeks
1500 RPM	Over 150 °F	Dirty	Weekly
Any speed	Up to 150 °F	Dirty	1 week to 1 month
Any speed	Over 150 °F	Dirty	Daily to 1 week
Any speed	Any temperature	Very dirty	Daily to 1 week
Any speed	Any temperature	Extreme Conditions	Daily to 1 week

TENSIONING V-BELT DRIVES

1. Ideal tension is the lowest tension at which the belt will not slip under peak load conditions.
2. Check tension frequently during the first 24-48 hours of operation.
3. Over-tensioning shortens the belt and bearing life.
4. Keep belts free from foreign material that may cause slip.
5. Make V-drive inspection on a periodic basis. Re-tension when slipping occurs. Never apply belt dressing as this will damage the belt and cause early failure.

Check and tighten belt tension. The following procedure is recommended for tightening belts:

- a. Measure span "X" shown in Figure A.
- b. At the center of span length "X", apply a force perpendicular to the span and large enough to deflect belt 1/64" for each inch of span length. Example – the required deflection for a 40" span would be 40/64" or 5/8".
- c. Compare the force applied with the values given in the table below. If the force is between the minimum and maximum range shown, the drive tension should be satisfactory. A force below the minimum value indicates an under tightened belt and a force that exceeds the maximum value indicates an over tightened belt.

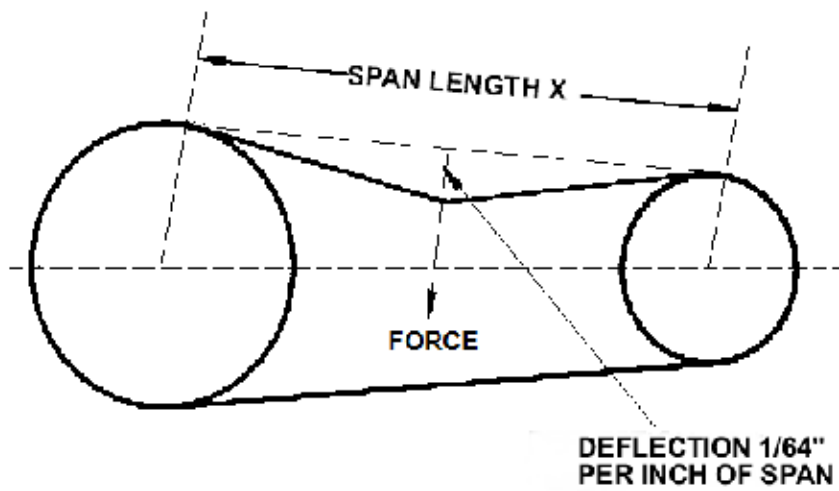

BELT CROSS SECTION (Marked on Belt)	MOTOR PULLEY PITCH DIAMETER	DEFLECTION FORCE	
		MINIMUM	MAXIMUM
A	3.0" – 3.6"	2.62 lbs	3.25 lbs
	3.8" – 4.8"	3.0 lbs	4.0 lbs
	5.0" – 7.0"	3.25 lbs	5.0 lbs
B	3.4" – 4.2"	3.0 lbs	5.0 lbs
	4.4" – 5.6"	4.0 lbs	5.87 lbs
	5.8" – 8.6"	5.25 lbs	7.87 lbs



Product Warranty

Warranty on Tempeff Heat Recovery devices is one (1) year from unit start-up date or 15 months from date of shipment from our factory, whichever comes first. Tempeff heat exchanger cells are warranted against material or manufacturing defects for a period of 10 years.

Our warranty applies for original shipment on all parts and components fabricated by or installed by us with the exception of air filters, and blower belts.

Within the one year warranty, replacement parts will be shipped collect and charged to customer account with credit being issued after receipt of, and examination of the returned parts: freight prepaid to the factory.

This warranty does not include freight, labor, or sales tax that may be incurred by the purchasers and is subject to the following conditions:

- 1) The unit shall be installed by a qualified heating or ventilation contractor in accordance with the provisions of the service manual.
- 2) The unit shall have been installed in accordance with all national and local codes.
- 3) The unit shall have been subject to only normal use in service and shall not have been misused, neglected, altered or otherwise damaged.
- 4) The unit shall have been operated within its published capacity and with the prescribed fuel.
- 5) All automatic controls shall have been operative at all times.
- 6) The heat exchanger has not been subjected to corrosive environments
- 7) There is no evidence of tampering or deliberate destruction.
- 8) Frost damage to coils is not covered by this warranty

No representative of Tempeff or any of its distributors or dealers is authorized to assume for Tempeff any other obligations or liability in connection with this product, nor alter the terms of this warranty in any way. This warranty is limited to the express provisions contained herein and does not extend to liability for labor or travel costs incurred in replacing defective parts.

Authorization to return any alleged defective parts must be obtained from the factory before the part is transported and the owner shall prepay the transportation charges for any alleged defective parts. Tempeff will not accept charges for parts purchased unless the conditions of this warranty have been satisfied.

The express warranties herein contained are in lieu of other warranties, expressed or implied, including the warranty of merchantability and of fitness for any particular purpose. Tempeff shall not be liable for damages, including special, incidental, or consequential damages arising out of or in connection with the performance of the heat recovery devices, or its use by the owner. Tempeff liability is limited exclusively to repair and or replacement of the defective part. Parts can be obtained from Tempeff, 675 Washington Ave, Winnipeg, Manitoba, R2K 1M4, on the basis that credit will be issued if defective parts returned qualify for replacement pursuant to the terms and conditions of this warranty.

Schneider M172P Controller Guide



Date:	May 13, 2021	No:	FWI004
Scope:	Controller guide	Products:	All product lines

Instruction Details:

Home Screen & Navigation

Digital inputs indicate input is On. If input is Off, the input# will not be shown.

Analog inputs with status bar to indicate 0 to 100% input status

Status LED	Solid	Flashing
Green	Powered	
Red	Low limit alarm	Damper alarm
Yellow	Recirculation	Heat recovery
Green		Free cooling

Navigation buttons to adjust settings & to jump between fields

Operating status and alarm codes

OK to open pages, to enter & save new values

Digital outputs indicate output is On. If output is Off, the output# will not be shown.

Analog outputs with status bar to indicate 0 to 100% output status

Main Menu

1. The controller starts up with the Home screen.
2. Press OK to enter the MENU page.
3. Use navigation buttons to select page of interest & press OK.

Temperature readings of available temp. sensors

X to exit page. Move cursor to X & press OK.

°F / °C selection for all temperature readings & setpoints

Cursor at ERV page

ERV Menu

1. On the MENU page, navigate to ERV & press OK to open the ERV page.
2. To edit GT3 setpoint, move to the field highlighted below and press OK.
3. Use the Left & Right arrow to move between digits, Up & Down arrows to adjust the value.
4. Press OK to save new setpoint.

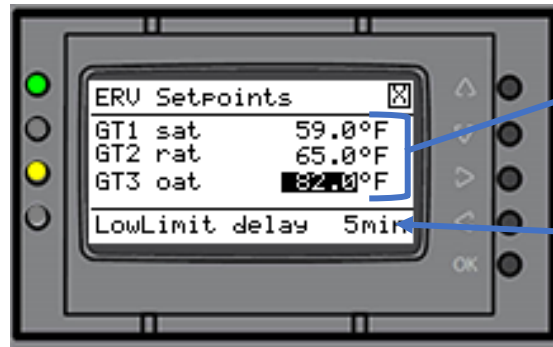

GT setpoints for heat recovery/free cooling

On-delay for low limit alarm

Other Sample Pages

1. Custom pages & subpages may vary, depending on unit layout & control features.

HEAT & HEATING PID

1. On the MENU page, navigate to HEAT & press OK to open the HEAT page.
2. To edit heat ambient lockout, move to the field highlighted below and press OK.
3. Use the Left & Right arrow to move between digits, Up & Down arrows to adjust the value.
4. Press OK to save new setpoint.
5. Move down to the PID field & press OK to open the HEATING PID page.

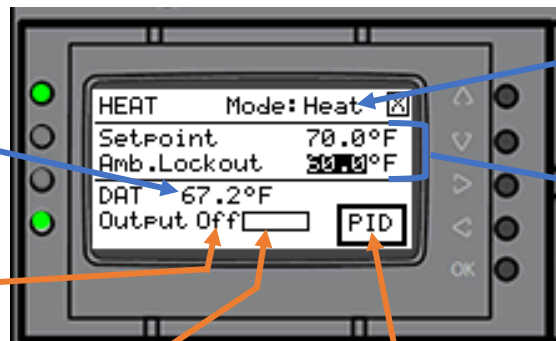

Discharge Air Temperature current temp. reading

Heat enable status. If On, the output is energized.

Heat/Cool mode selection

DAT setpoints & ambient lockout for heating mode

Heat analog output. Status bar will show 0 to 100% heating output

PID field to open subpage to tune heating PID parameters



PID Throttling range

PID integral, derivative & anti reset windup time. Settings in 0.1seconds.

BACNET

Note: This controller is Bacnet capable. Bacnet must be requested at time of order.

1. If ordered with Bacnet, go to the MENU page, navigate to BACnet & press OK to open the page.
2. Depending on the Bacnet protocol in the building, select either RS-485 or Ethernet to open the appropriate sub-page for further settings.

Note: Default protocol is Bacnet MSTP. Bacnet IP is disabled from factory.

3. Match communication settings to the BMS communication settings.
4. Close page & cycle power to save changes.

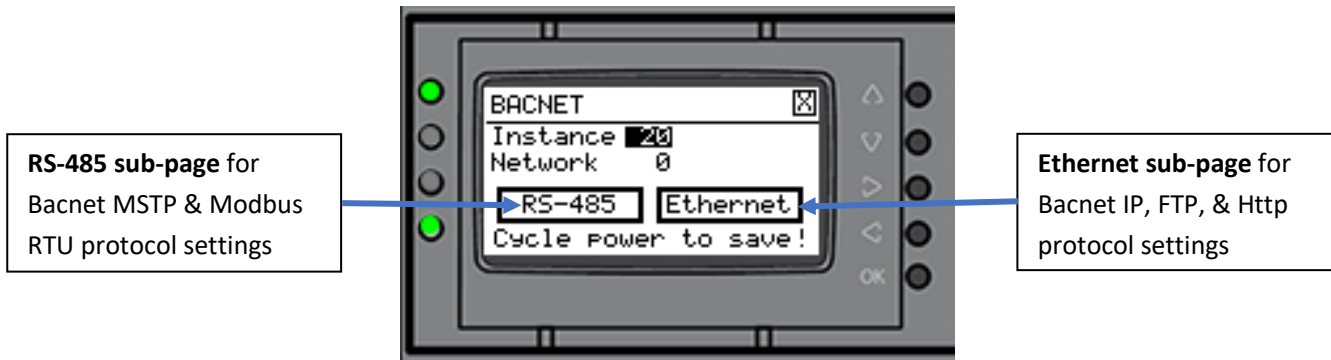

BACnet/IP over UDP

Note: Default protocol is Bacnet MSTP. Bacnet IP is disabled from factory.

1. If ordered with Bacnet, go to the MENU page, navigate to BACnet & press OK to open the page.
2. Navigate to the RS-485 field & press OK.
3. Move cursor to the Protocol field & change protocol to Modbus RTU.



RS-485 protocol select
ModbusRTU to disable
Bacnet MSTP

4. Close the RS-485 page to go back to the Bacnet page.
5. Navigate to the Ethernet field & press OK.
6. Set the controller IP address and Gateway to IP 192.168.X.X.
7. Set BcnIP to 0 to enable Bacnet IP communication.
8. Close the page & cycle power to save changes.

Bacnet IP port 0=enabled
65535=port disabled

FTP port 0=default port
21; 65535=port disabled

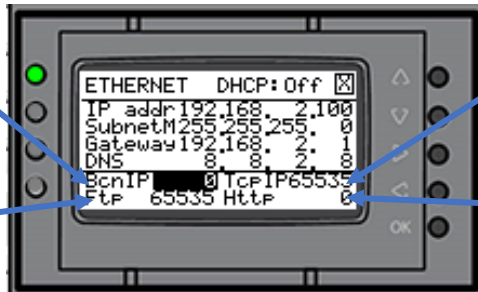

Tcp/IP port 0=enabled;
65535=port disabled

HTTP port 0=default port
80; 65535=port disabled

Optional – Embedded WebServer: Configure Ethernet with a laptop

1. Navigate to the Ethernet page on the controller. Confirm HTTP port is set to 0.
2. Connect laptop to the controller's ethernet port.
3. Open a web browser & enter IP address of the controller.
4. Go to "Click here to enter site" on the embedded web server page. When prompted, enter User:administrator; password:tempeff1
5. Click on Ethernet in Parameters Menu to view current Ethernet settings. Confirm Port_BACnet_PI set to 0.
6. Cycle power to save changes.

← → 🔒 Not secure | 192.168.2.100 ☆ 🌐 📄

- Controller embedded Web server -

[Click here to enter site](#)

Change Administrator password (only if logged as Administrator)

Name	Value
HTTP_AdminUserName	*****
HTTP_AdminPswOld	*****
HTTP_AdminPswNew	*****
HTTP_AdminConfirm	<input type="checkbox"/>
HTTP_AdminConfirmStatus	

Embedded WebServer
click to access controller parameters

Bacnet IP Port set to 0 to enable. Cycle power to save changes

← → 🔒 Not secure | 192.168.2.100/evopet.htm ☆ 🌐 📄

Index

Ethernet parameters

Name	Value
Port_HTTP_PI	0
Port_FTP_PI	65535
Port_BACnet_PI	0
Port_ETH_PI	65535
Ip_ETH_PI	192, 168, 2, 100
DefGtWY_ETH_PI	192, 168, 0, 1
NetMsk_ETH_PI	255, 255, 255, 0
PriDNS_ETH_PI	8, 8, 2, 8
SecDNS_ETH_PI	8, 8, 4, 4
EnableDHCP_ETH_PI	FALSE
MAC_ETH_PI	0, 24, 187, 2, 120, 197

Control Program Update

1. Save revised Schneider USB program files to an empty USB stick.

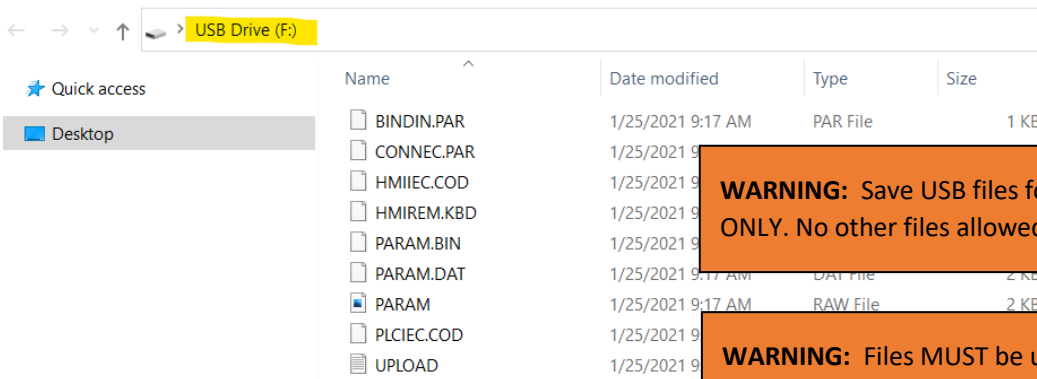

2. Make sure controller is powered. Loss of power during download will corrupt the controller.
3. Plug USB stick into controller.
4. Yellow LED will turn on to indicate it is loading.
5. Yellow LED turns off, 2nd green LED turns on when download complete.
6. Remove USB stick.
7. Cycle power to restart controller.

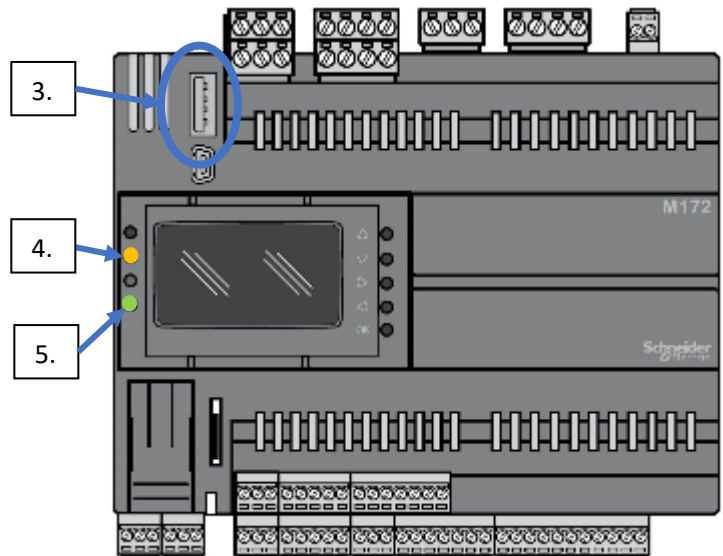



START-UP CHECK SHEET

Unit Model Number: _____ Unit Serial Number: _____

Owner: _____ Owner Phone #: _____

Address: _____

Installing Contractor: _____ Start-up Mechanic: _____

Main Voltage

Incoming Voltage (3 phase Units) L1 _____ L2 _____ L3 _____

Running Voltage (3 phase units) L1 _____ L2 _____ L3 _____

Incoming Voltage (1 Phase units) L1-L2 _____ Running Voltage L1-L2 _____

Secondary Voltage _____

Amperage

Supply Air motor: Rating Plate voltage: _____

Rated amps: _____ Measured amps: L1 _____ L2 _____ L3 _____

Return Air motor: Rating Plate voltage: _____

Rated amps: _____ Measured amps: L1 _____ L2 _____ L3 _____

Variable Frequency Drives (If Equipped)

Supply VFD Operating Frequency: _____

Measured Input Volts: L1 _____ L2 _____ L3 _____

Amps: L1 _____ L2 _____ L3 _____

Measured Output Volts: L1 _____ L2 _____ L3 _____

Amps: L1 _____ L2 _____ L3 _____

Exhaust VFD Operating Frequency: _____

Measured Input Volts: L1 _____ L2 _____ L3 _____

Amps: L1 _____ L2 _____ L3 _____

Measured Output Volts: L1 _____ L2 _____ L3 _____

Amps: L1 _____ L2 _____ L3 _____

Air Flow/Performance

Has the Unit Been Air Balanced: Y _____ N _____ Date: _____

Upper Heat Exchanger Pressure Drop: _____ Exhaust Flow: _____
Intake Flow: _____

Lower Heat Exchanger Pressure Drop: _____ Exhaust Flow: _____
Intake Flow: _____

